

DS3

SOLENOID OPERATED DIRECTIONAL CONTROL VALVE

SUBPLATE MOUNTING ISO 4401-03

p max 350 bar
Q max 100 l/min

MOUNTING INTERFACE

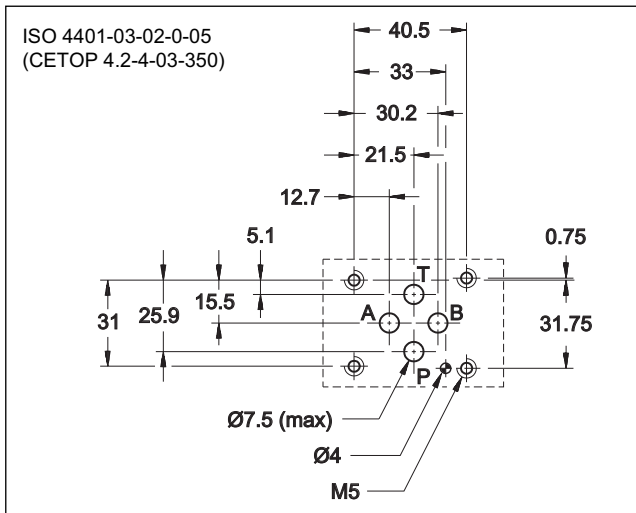

OPERATING PRINCIPLE

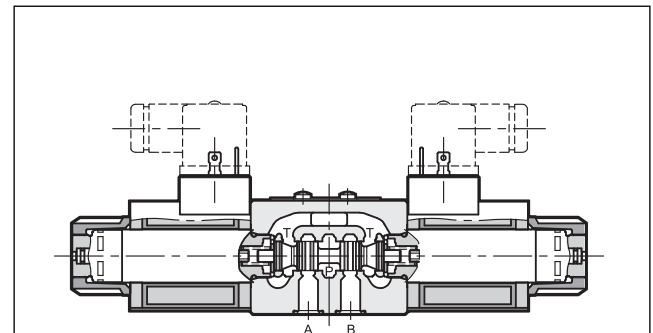

- Direct acting, subplate mounting directional control valve, with mounting surface according to ISO 4401-03 standards.
- The valve is supplied with 3 or 4 ways design, with 2 or 3 positions with a wide range of spools.
- The valve body is made with high strength iron castings provided with wide internal paths in order to minimize the flow pressure drop. Wet armature solenoids with interchangeable coils are used (for further information on solenoids see par. 7).
 - The valve is available with DC or AC solenoids. DC solenoids can also be fed with AC power supply, by using connectors with a built-in rectifier bridge (see paragraphs 6.4 and 7.2).
 - The DC valve is also available in a soft-shifting version (see par. 14).
 - The DC valve is also available with zinc-nickel coating that ensures a salt spray resistance up to 600 hours .
 - It is available a version with UL certified 24V DC coils for Canada and the United States. (see par. 15).
 - Alternative to the standard manual override there are lever, push, boot and mechanical detent devices.

PERFORMANCES

(obtained with mineral oil with viscosity of 36 cSt at 50°C)

	bar	CC		CA	
		210	350	160	
Maximum operating pressure: - P - A - B ports - T port					
Maximum flowrate	l/min	100			
Pressure drops Δp -Q	see paragraph 4				
Operating limits	see paragraph 6				
Electrical features	see paragraph 7				
Electrical connections	see paragraph 11				
Ambient temperature range	°C	-20 / +50			
Fluid temperature range	°C	-20 / +80			
Fluid viscosity range	cSt	10 + 400			
Fluid contamination degree	according to ISO 4406:1999 class 20/18/15				
Recommended viscosity	cSt	25			
Mass:					
single solenoid valve	kg	1,5		1,4	
double solenoid valve	kg	2		2	

1 - IDENTIFICATION CODE

	D	S	3	-		/	11	-		/	
--	----------	----------	----------	---	--	---	-----------	---	--	---	--

Solenoid operated directional control valve

ISO 4401-03 size

Spool type (see paragraph 3)

S*	RSA*	TA	RK
SA*	RSB*	TB	
SB*		TA*	
		TB*	

Series: _____
(the overall and mounting dimensions remain unchanged from 10 to 19)

Seals: _____
N = NBR seals for mineral oil (**standard**)
V = FPM seals for special fluids

DC power supply _____

D12 = 12 V
D14 = 14 V
D24 = 24 V
D28 = 28 V
D48 = 48 V
D110 = 110 V
D125 = 125 V
D220 = 220 V
D00 = valve without coils (see **NOTE 1**)

AC power supply

A24 = 24 V - 50 Hz
A48 = 48 V - 50 Hz
A100 = 100 V - 50 Hz / 100 V - 60 Hz
A110 = 110 V - 50 Hz / 120 V - 60 Hz
A230 = 230 V - 50 Hz / 240 V - 60 Hz
A00 = valve without coils (see **NOTE1**)
F110 = 110 V - 60 Hz
F220 = 220 V - 60 Hz

NOTE 1 : Coils locking ring and related OR are supplied together with valves.

NOTE 2: The standard valve is supplied with surface treatment of phosphating black.
The zinc-nickel finishing on the valve body makes the valve suitable to ensure a salt spray resistance up to **240** hours. For a salt spray resistance up to **600** hours refer to paragraph 16.
(test operated according to UNI EN ISO 9227 standards and test evaluation operated according to UNI EN ISO 10289 standards).

Option:
/ W7 = Zinc-nickel surface treatment (see **NOTE 2**)
Omit if not required

Manual override:
omit for override integrated in the tube (**standard**)
CM = manual override, boot protected
CH = lever manual override (only for DC version)
The device is not available for TB, TB* and RSB* spools.
RSA* spools: available only for RSA1 and RSA2.
CP = push manual override (only for DC version)
CK = knob manual override (only for DC version)
CPK = push manual override with mechanical retention (only for DC version)

Coil electrical connection (see par. 11):
K1 = plug for connector type EN 175301-803 (ex DIN 43650) (**standard**)
K2 = plug for connector type AMP JUNIOR (available on **D12** and **D24** coils only)
K7 = plug DEUTSCH DT04-2P for male connector type DEUTSCH DT06-2S (available on **D12** and **D24** coils only)

2 - HYDRAULIC FLUIDS

Use mineral oil-based hydraulic fluids HL or HM type, according to ISO 6743-4. For these fluids, use NBR seals (code N). For fluids HFDR type (phosphate esters) use FPM seals (code V). For the use of other fluid types such as HFA, HFB, HFC, please consult our technical department.

Using fluids at temperatures higher than 80 °C causes a faster degradation of the fluid and of the seals characteristics. The fluid must be preserved in its physical and chemical characteristics.

3 - SPOOL TYPE

Type **S***:
2 solenoids - 3 positions
with spring centering

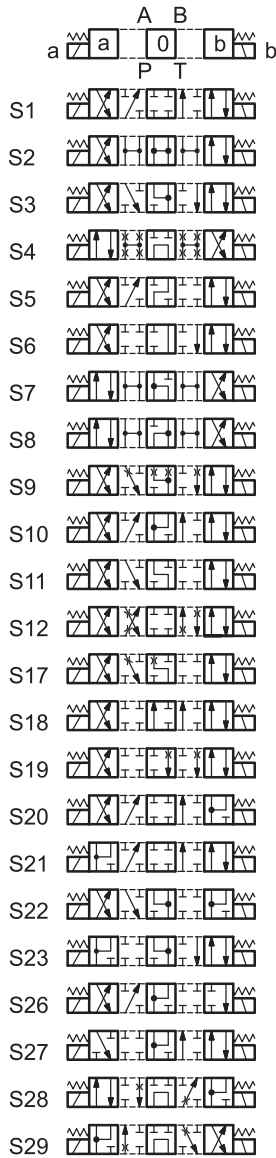

Type **RK**:
2 solenoids - 2 positions
with mechanical retention

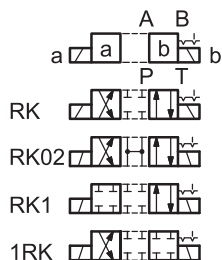

Type **SA***:
1 solenoid side A
2 positions (central + external)
with spring centering



Type **RSA***:
1 solenoid side A
2 positions (external + central)
with return spring

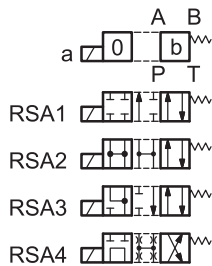

Type **TA**:
1 solenoid side A
2 external positions
with return spring

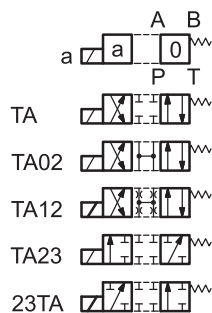

Type **TA***:
1 solenoid side A
2 positions with return spring



Type **SB***:
1 solenoid side B
2 positions (central + external)
with spring centering

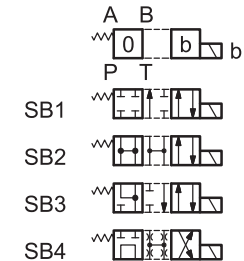

Type **RSB***:
1 solenoid side B
2 positions (external + central)
with return spring

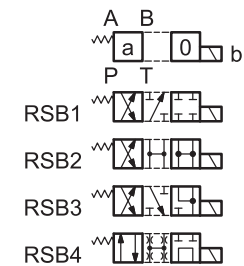

Type **TB**:
1 solenoid side B
2 external positions
with return spring

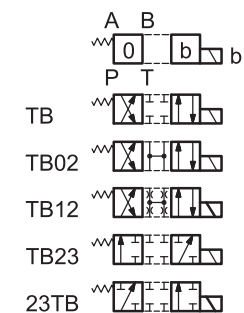

Type **TB***:
1 solenoid side B
2 positions with return spring

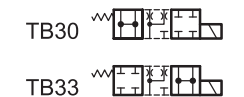

Besides the diagrams shown, which are the most frequently used, other special versions are available: consult our technical department for their identification, feasibility and operating limits.

4 - PRESSURE DROPS Δp -Q

(obtained with viscosity 36 cSt at 50 °C)

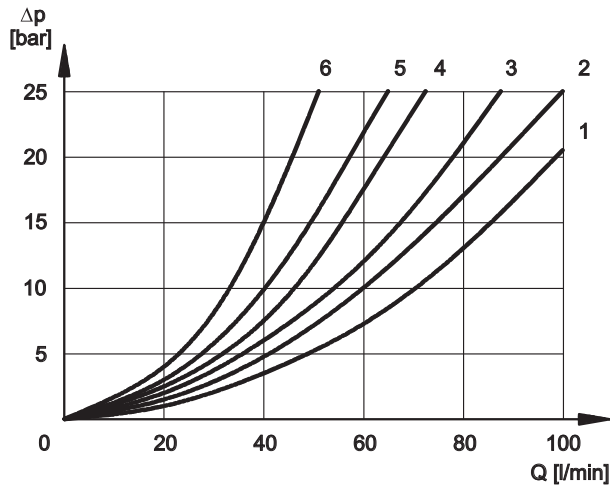

ENERGIZED POSITION

SPOOL TYPE	FLOW DIRECTION			
	P→A	P→B	A→T	B→T
	CURVES ON GRAPH			
S1, SA1, SB1	2	2	3	3
S2, SA2, SB2	1	1	3	3
S3, SA3, SB3, RSA3, RSB3	3	3	1	1
S4, SA4, SB4, RSA4, RSB4	5	5	5	5
S5	2	1	3	3
S6	2	2	3	1
S7, S8	4	5	5	5
S9	2	2	3	3
S10	1	3	1	3
S11	2	2	1	3
S12, S17, S19	2	2	3	3
S18	1	2	3	3
S20, S22	1	5	2	
S21, S23	5	1		2
S28	6	5	-	6
S29	5	6	6	-
TA, TB	3	3	3	3
TA02, TB02	2	2	2	2
TA23, TB23	3	3		
RK, RK02, RK1, 1RK	2	2	2	2

For pressure drops between A and B lines of spools S10, S20, S21, S22 and S23, which are used in the regenerative diagram, refer to curve 5.

DE-ENERGIZED POSITION

SPOOL TYPE	FLOW DIRECTION				
	P→A	P→B	A→T	B→T	P→T
	CURVES ON GRAPH				
S2, SA2, SB2					2
S3, SA3, SB3, RSA3, RSB3			3	3	
S4, SA4, SB4, RSA4, RSB4					3
S5		4			
S6				3	
S7, S8			6	6	3
S10	3	3			
S11			3		
S18	4				
S22, S23			3	3	
S28, S29				6	

5 - SWITCHING TIMES

The values indicated are obtained according to ISO 6403 standard, with mineral oil viscosity 36 cSt at 50°C.

SPOOL TYPE	TIMES [ms]	
	ENERGIZING	DE-ENERGIZING
CC	25 ÷ 75	15 ÷ 25
CA	10 ÷ 25	15 ÷ 40

6 - OPERATING LIMITS

The curves define the flow rate operating fields according to the valve pressure of the different versions. The values have been obtained according to ISO 6403 norm with solenoids at rated temperature and supplied with voltage equal to 90% of the nominal voltage. The value have been obtained with mineral oil, viscosity 36 cSt, temperature 50 °C and filtration according to ISO 4406:1999 class 18/16/13.

The limits for TA02 and TA spools refer to the 4-way operation. The operating limits of a 4-way valve in 3-way operation or with port A or B plugged or without flow are shown in the chart on the next page. The performance of the DC solenoid powered by AC with rectifier connectors are at par. 6.4. The performances of the soft-shift valve are shown at par. 14.

6.1 - Valves in standard operation

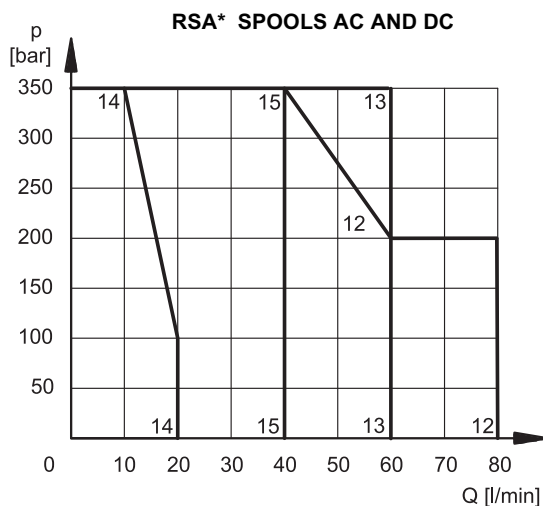
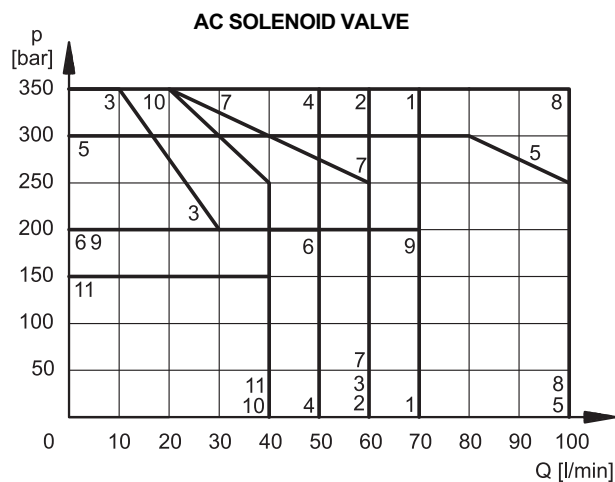
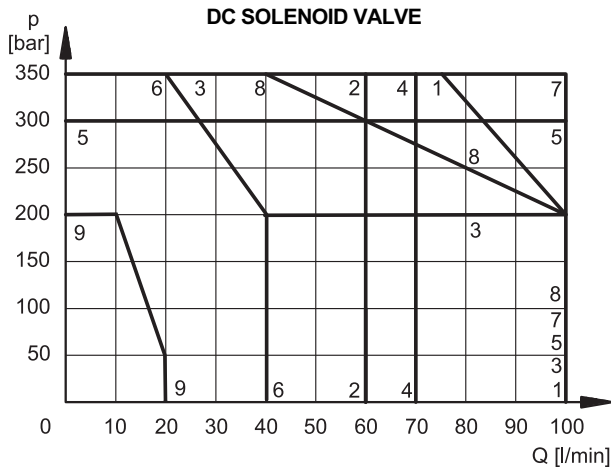

DC SOLENOID VALVE

SPOOL	CURVE	
	P→A	P→B
S1,SA1,SB1	1	1
S2,SA2,SB2	2	2
S3,SA3,SB3	3	3
S4,SA4,SB4	4	4
S5	5	5
S6	4	6
S7	4	4
S8	4	4
S9	7	7
S10	7	7
S11	4	6
S12	1	1
S17	4	4
S18	5	5
S19	4	4
S20	6*	6
S21	6	6*
S22	6	6
S23	6	6
S28	9*	9*
S29	9*	9*
TA, TB	7	7
TA02, TB02	8	8
TA23, TB23	2	2
RK	7	7
RK02	8	8
RK1, 1RK	7	7

AC SOLENOID VALVE

SPOOL	CURVE	
	P→A	P→B
S1,SA1,SB1	1	1
S2,SA2,SB2	2	2
S3,SA3,SB3	3	3
S4,SA4,SB4	2	2
S5	5	5
S6	6	6
S7	4	4
S8	4	4
S9	7	7
S10	8	8
S11	6	6
S12	2	2
S17	7	7
S18	5	5
S19	7	7
S20	10*	10
S21	10	10*
S22	10*	10
S23	10	11*
S28		
S29		
TA, TB	1	1
TA02, TB02	1	1
TA23, TB23	2	2
RK	8	8
RK02	9	9
RK1, 1RK	8	8

* Performance obtained for a valve with A and B lines connected the one to the piston-side chamber and the other to the rod-side chamber of a double-acting cylinder with area ratio 2:1.

SPOOL	CURVE
RSA1	12
RSA2	13
RSA3	14
RSA4	15

6.2 - 4-way valve in 3-way operation

Operating limits of a 4-way valve in 3-way operation or with port A or B plugged or without flow.

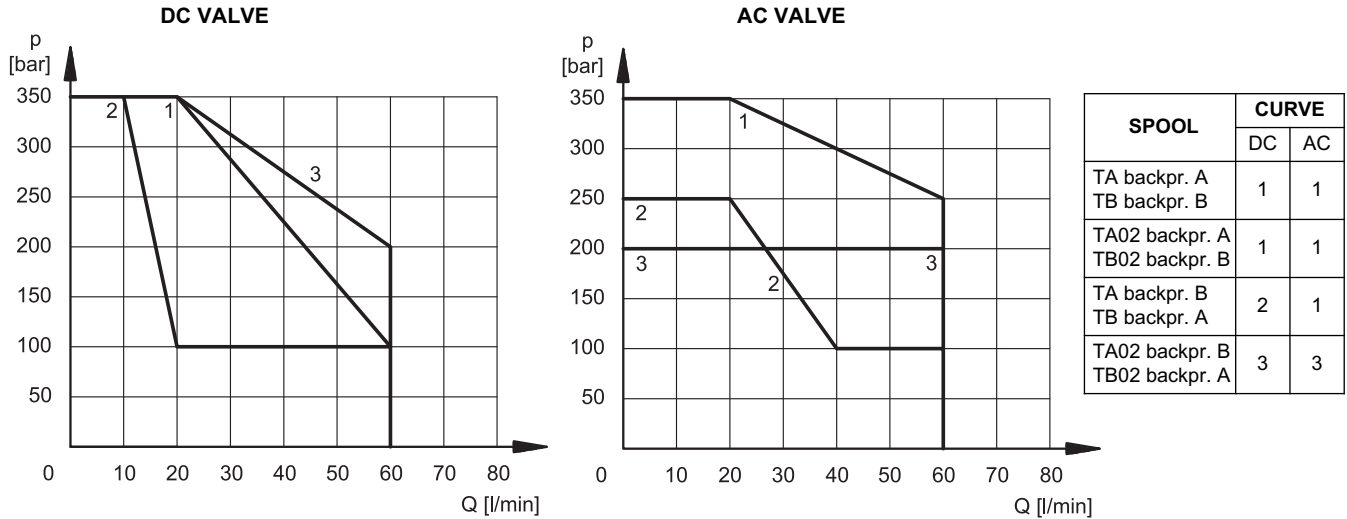

6.3 - AC solenoid valve with coil A110 fed with 110V - 60 Hz

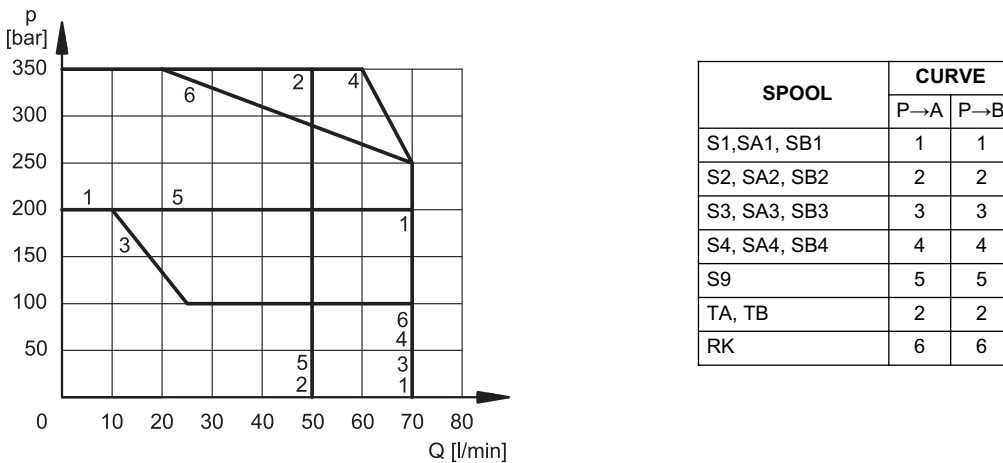

6.4 - Operating limits for DC solenoid valves fed with AC with rectifier connectors

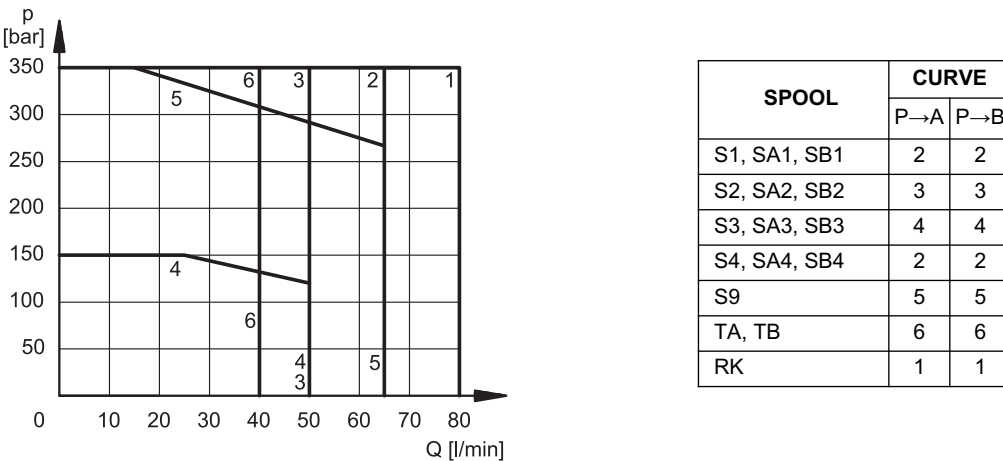

7 - ELECTRICAL FEATURES

7.1- Solenoids

These are essentially made up of two parts: tube and coil. The tube is threaded into the valve body and includes the armature that moves immersed in oil, without wear. The inner part, in contact with the oil in the return line, ensures heat dissipation. The coil is fastened to the tube by a threaded ring, and can be rotated 360°, to suit the available space.

Protection from atmospheric agents IEC 60529

The IP protection degree is guaranteed only with both valve and connectors of an equivalent IP grade, correctly connected and installed.

electric connection	electric connection protection	whole valve protection
K1 EN 175301-803 (ex DIN 43650)	IP66	IP65
K2 AMP JUNIOR	IP65/67	
K7 DEUTSCH DT04 male	IP66/IP68/IP69 IP69K*	

(*) The IP69K protection degree is not taken into account in IEC 60529 but it is included in ISO 20653.

SUPPLY VOLTAGE FLUCTUATION	± 10% Vnom
MAX SWITCH ON FREQUENCY	18.000 ins/hr
DUTY CYCLE	100%
ELECTROMAGNETIC COMPATIBILITY (EMC) (NOTE)	In compliance with 2014/30/EU
LOW VOLTAGE	In compliance with 2014/35/EU
CLASS OF PROTECTION : Coil insulation (VDE 0580) Impregnation: DC valve AC valve	class H class F class H

NOTE: In order to further reduce the emissions, with DC supply, use of type H connectors is recommended. These prevent voltage peaks on opening of the coil supply electrical circuit (see cat. 49 000).

7.2 - Current and absorbed power for DC solenoid valve

The table shows current and power consumption values of the DC coils.

Using connectors type "D" (see cat. 49 000) with embedded bridge rectifier it is possible to feed DC coils (starting from 48V voltage) with alternating current (50 or 60 Hz), considering a reduction of the operating limits (see diagram at section 6.4).

Coils for direct current (values ± 10%)

	Nominal voltage [V]	Resistance at 20°C [Ω]	Current consumpt. [A]	Power consumpt [W]	Coil code		
					K1	K2	K7
D12	12	4,4	2,72	32,7	1903080	1903100	1902940
D14	14	7,2	1,93	27	1903086		
D24	24	18,6	1,29	31	1903081	1903101	1902941
D28	28	26	1,11	31	1903082		
D48	48	78,6	0,61	29,5	1903083		
D110	110	423	0,26	28,2	1903464		
D125	125	550	0,23	28,6	1903467		
D220	220	1692	0,13	28,2	1903465		

7.3 - Current and absorbed power for AC solenoid valve

The table shows current and power consumption values at inrush and at holding, for AC coils.

Coils for alternating current (values ± 5%)

Suffix	Nominal Voltage [V]	Freq. [Hz]	Resistance at 20°C [Ω] (±1%)	Current consumption at inrush [A] (±5%)	Current consumption at holding [A] (±5%)	Power consumption at inrush (±5%) [VA]	Power consumption at holding (±5%) [VA]	Coil Code K1
A24	24	50	1,46	8	2	192	48	1902830
A48	48		5,84	4,4	1,1	204	51	1902831
A100	100V-50Hz 100V-60Hz	50/60	23,3	2,27	0,49	227	49	1902836
				2,01	0,38	201	38	
A110	110V-50Hz 120V-60Hz		1,84	0,46	192	48	1902832	
			1,56	0,39	188	47		
A230	230V-50Hz 240V-60Hz		140	0,76	0,19	176	44	1902833
				0,6	0,15	144	36	
F110	110	60	26	1,6	0,4	176	44	1902834
F220	220		106	0,8	0,2	180	45	1902835

8 - OVERALL AND MOUNTING DIMENSIONS FOR DC SOLENOID VALVES

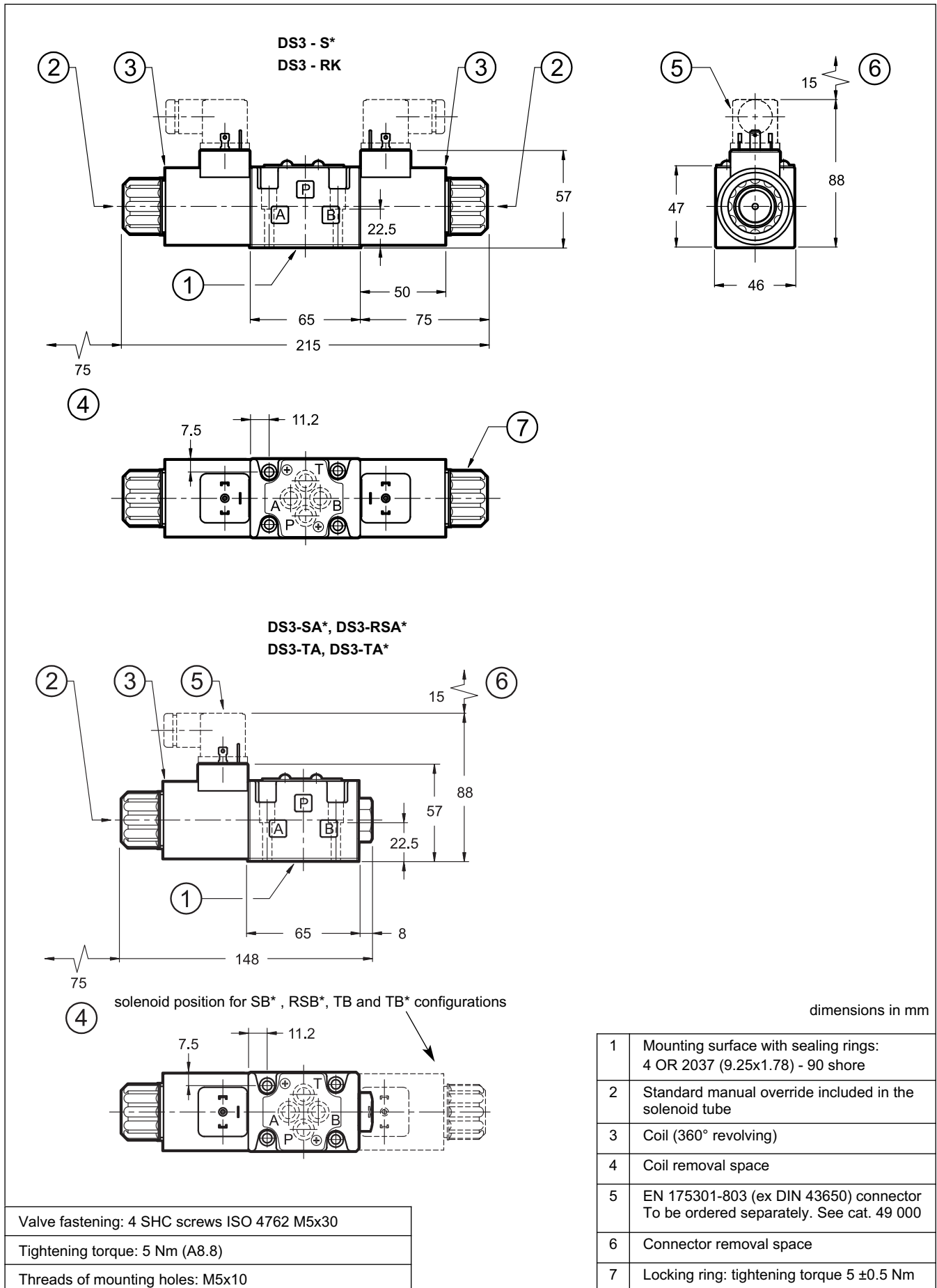

9 - OVERALL AND MOUNTING DIMENSIONS FOR AC SOLENOID VALVES

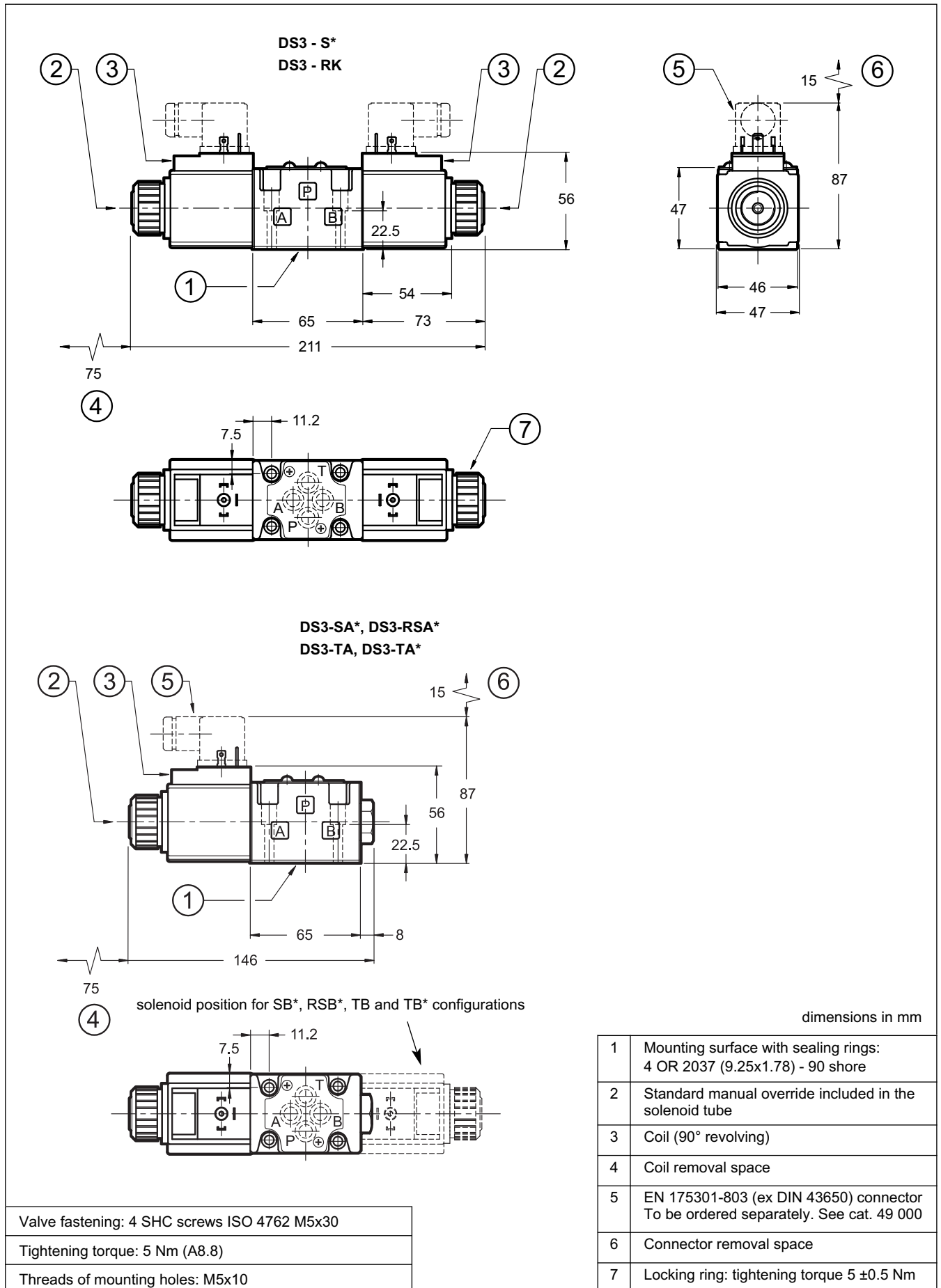

10 - INSTALLATION

Configurations with centering and return springs can be mounted in any position; type RK valves - without springs and with mechanical detent - must be mounted with the longitudinal axis horizontal.

Valve fixing takes place by means of screws or tie rods, with the valve mounted on a lapped surface, with values of planarity and smoothness that are equal to or better than those indicated in the drawing. If the minimum values of planarity and/or smoothness are not met, fluid leakages between valve and mounting surface can easily occur.

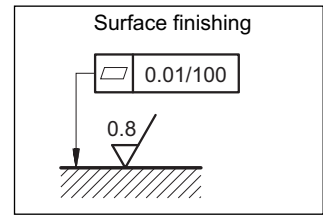

11 - ELECTRIC CONNECTIONS

connection for EN 175301-803
(ex DIN 43650) connector
code **K1 (standard)**
code **WK1** (W7 version only)

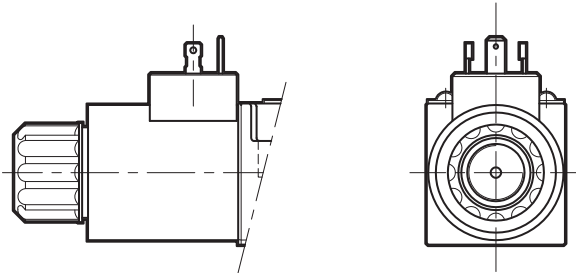

connection for AMP JUNIOR
connector
code **K2**



connection for
DEUTSCH DT06-2S male connector
code **K7**



connection for
DEUTSCH DT06-2S male connector
code **WK7** (W7 version only)
code **WK7D** (W7 version only - coil
with diode)



12 - ELECTRIC CONNECTORS

The valves are delivered without connectors. Connectors type EN 175301-803 (ex DIN 43650) for K1 connections can be ordered separately. See catalogue 49 000.

13 - MANUAL OVERRIDES

13.1 - Manual override, boot protected

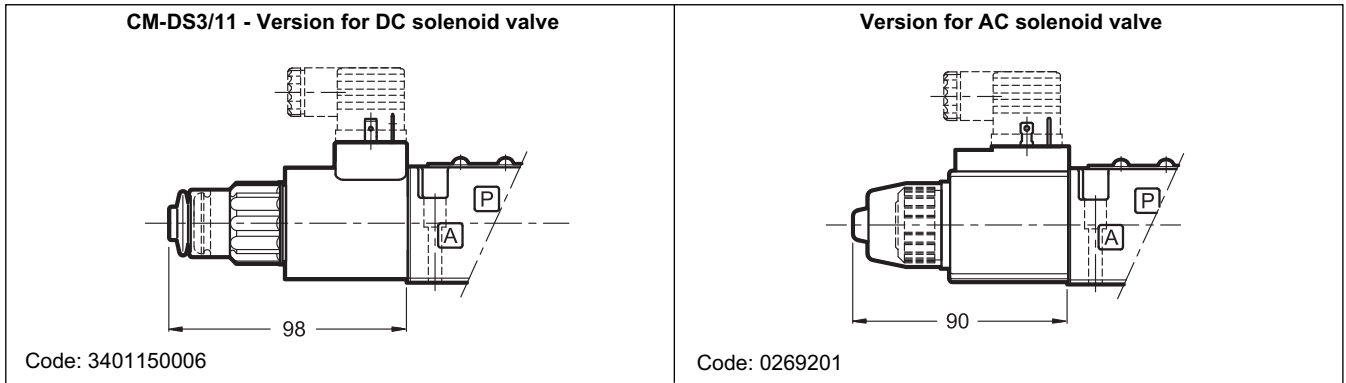

13.2 - CH-DS3/11 Lever manual override (only for DC solenoid valve)

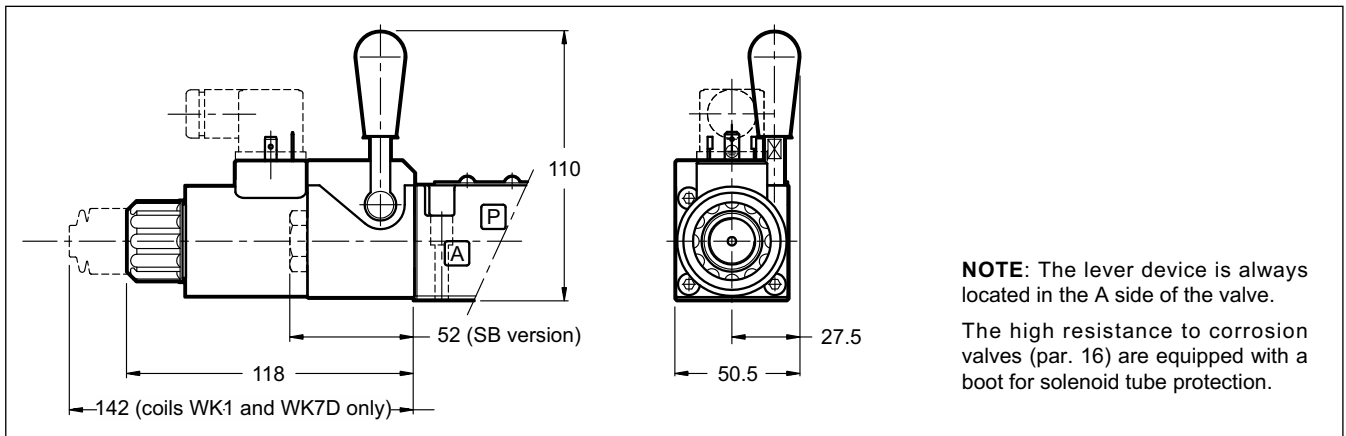

13.3 - CP-DS3/10 Push manual override (only for DC solenoid valve)

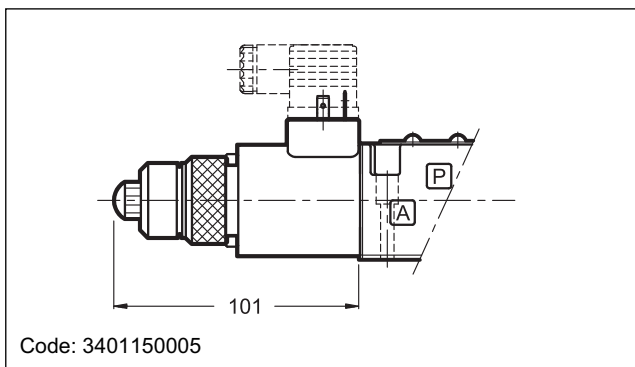

13.4 - CK-DS3/10 Knob manual override (only for DC solenoid valve)

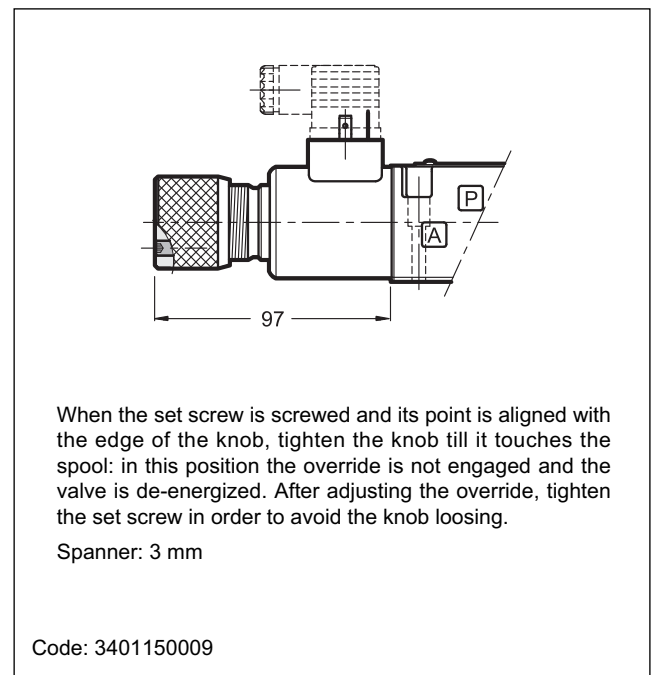

13.5 - CPK-DS3/10 Push manual override with mechanical retention (only for DC solenoid valve)

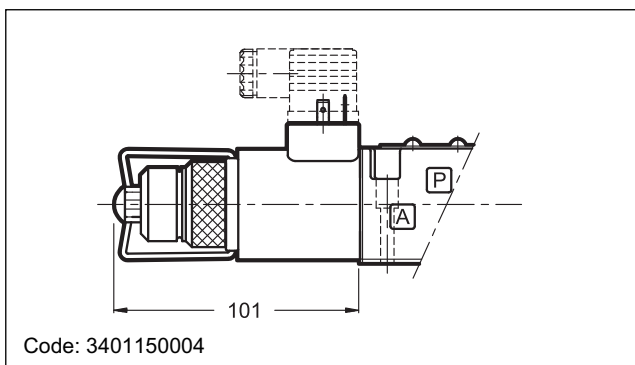

14 - SOFT-SHIFT VERSION FOR DC VALVE

14.1 - Identification code

	D	S	3	-		/	13	-			/	F		
--	----------	----------	----------	---	--	---	-----------	---	--	--	---	----------	--	--

Solenoid operated directional control valve

ISO 4401-03 size

Spool type

The hydraulic symbols of S2F and S4F are identical to those of S2 and S4 spools (p.2)

S1	TA12
S2F	TB12
S4F	TA23
S9	TB23
S12	

Series: _____
(the overall and mounting dimensions remain unchanged from 10 to 19)

Seals: _____

N = NBR seals for mineral oil (**standard**)
V = FPM seals for special fluids

Option:
/ **W7** = see par. 1

Manual override
(see par.1 and 13)

Soft-shifting

Coil electrical connection
(see par. 11):

K1 = plug for connector type
EN 175301-803 (ex DIN 43650) (**standard**)

K2 = plug for connector type AMP JUNIOR
(available on **D12** and **D24** coils only)

K7 = plug DEUTSCH DT04-2P for male
connector type DEUTSCH DT06-2S
(available on **D12** and **D24** coils only)

DC power supply

D12 = 12 V
D24 = 24 V
D28 = 28 V
D110 = 110 V
D220 = 220 V

This version enables hydraulic actuators to perform a smooth start and stop by reducing the speed of movement of the valve spool.

In this version, the S9 spool must be used instead of the S3 type.

The diagram on the side shows the operating limits of the spools available in the soft-shifting version, while the table shows the switching times.

The values indicated are obtained according to ISO 6403 standard, with mineral oil viscosity 36 cSt at 50°C.

The shifting time and characteristics curves are influenced by the viscosity (and thus by the temperature) of the operating fluid. Moreover, times can vary according to the flow rate and operating pressure values of the valve.

For correct operation of the soft-shifting ensure the solenoid tubes are always filled with oil. At this matter, we recommend to install a backpressure valve set at 1 + 2 bar on T line.

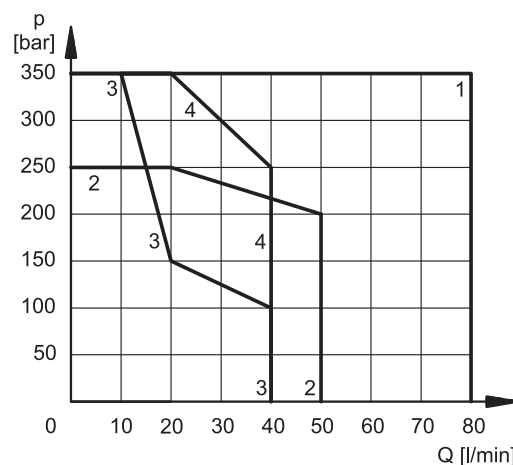

SPOOL	CURVE	TIMES [ms]	
		ENERGIZING	DE-ENERGIZING
S1, S12	1	350	200 + 300
S2F	2	400	100 + 250
S4F	4	350	150 + 300
S9	1	400	200 + 300
TA12, TB12	3	180	200 + 300
TA23, TB23		300	200 + 300

15 - VERSION WITH UL CERTIFIED COILS

15.1 - Identification code

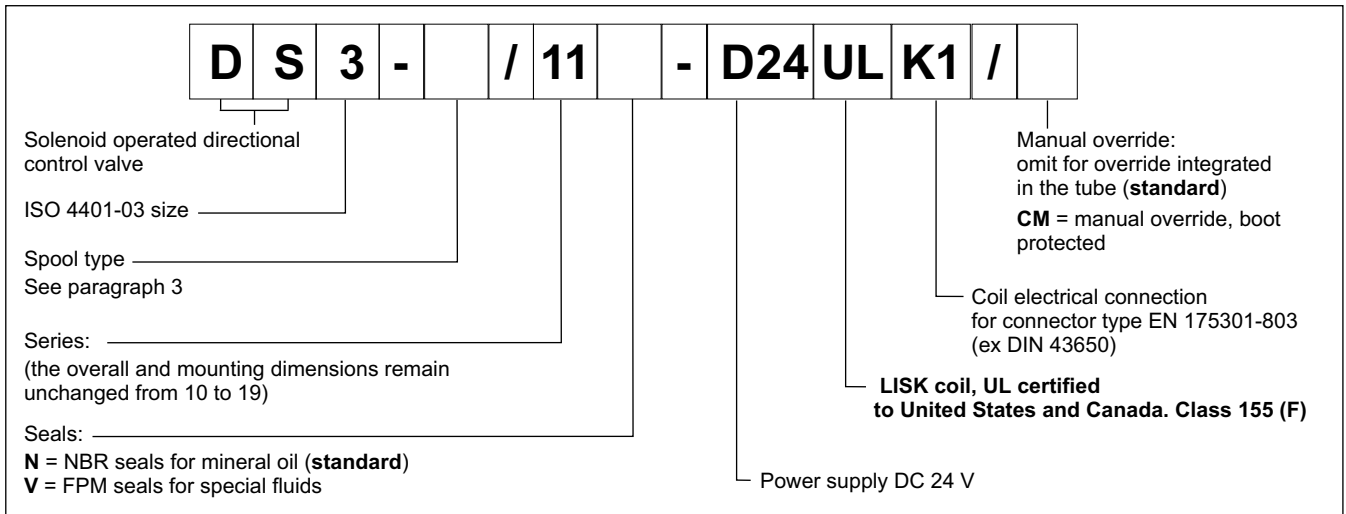

15.2 - UL file number

The UL database website provides informations about the certification, by entering the code MH29222 in the 'UL file number' field.

15.3 - Electrical features

(values ± 10%)

	Nominal voltage [V]	Resistance at 20°C [Ω]	Current consumpt. [A]	Power consumpt [W]	Coil code
D24ULK1	24	19.2	1.25	30	1903341

NOTE: Valves with UL coils must be ordered complete. **The UL coils are not interchangeable with those of standard valves.**

15.4 - Overall and mounting dimensions

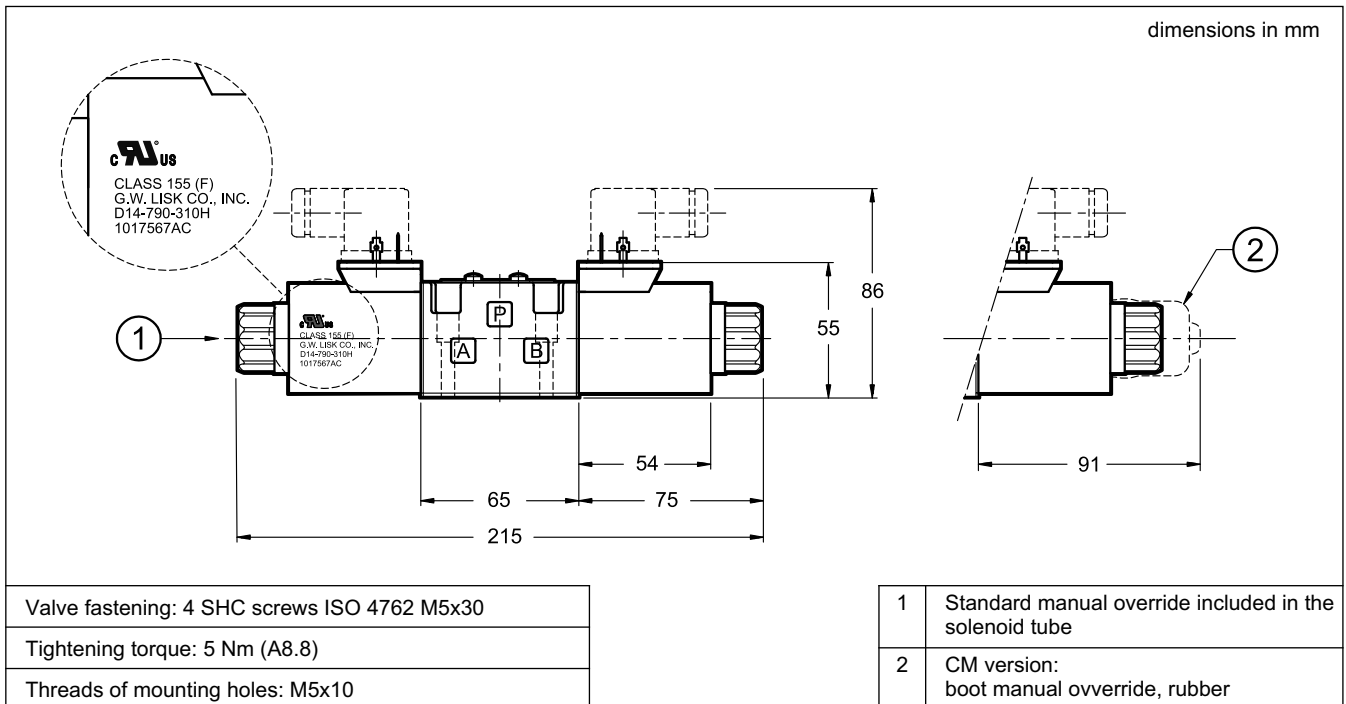

15.5 - Spare parts

UL certified coil: C22S3-D24ULK1/11
 Solenoid tube : NBR TD22-DS3-UL/11N
 viton TD22-DS3-UL/11V

Solenoid tube plunger: cod. 0119545
 Locking ring: cod. 0119546
 Seals : kit for standard DC valves

16 - HIGH CORROSION RESISTANCE VERSION

16.1 - identification code

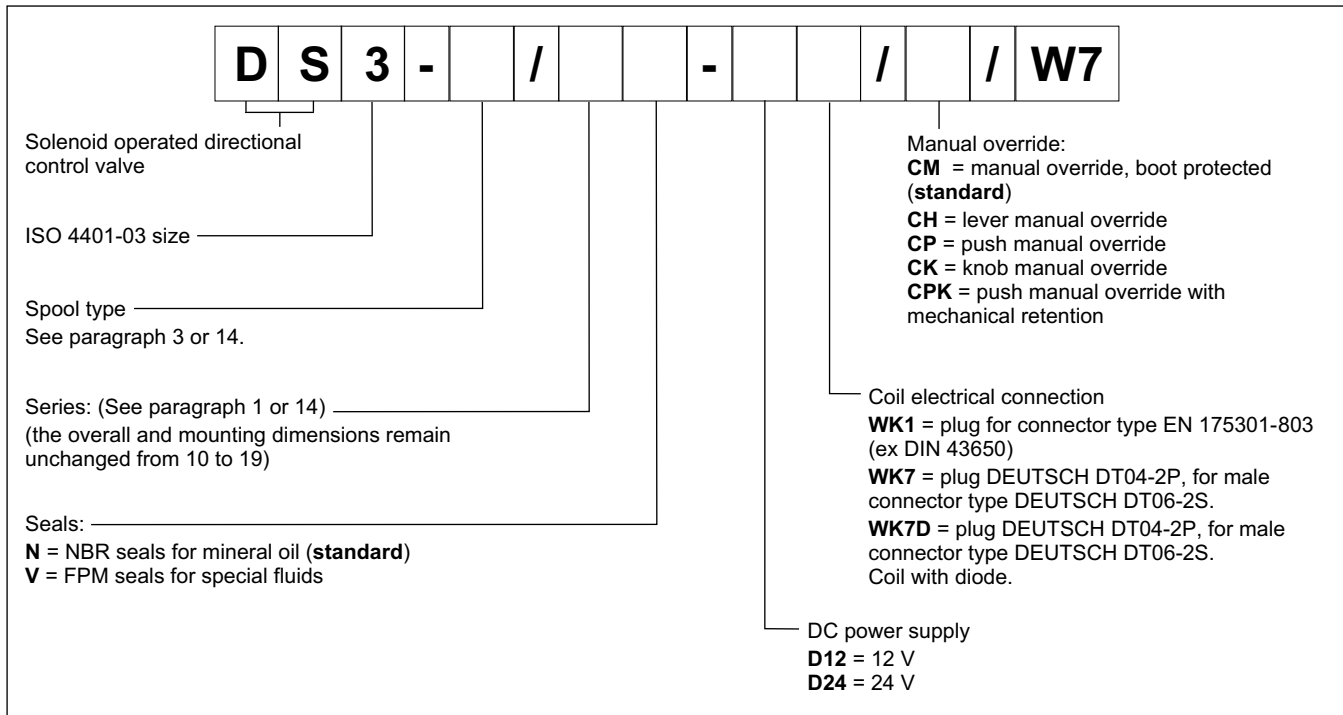

16.2 - Corrosion resistance

This version features the zinc-nickel coating on all exposed metal parts of the valve, making it resistant to exposure to the salt spray for **600** hours (test performed according to UNI EN ISO 9227 and assessment test performed according to UNI EN ISO 10289).

16.3 - DC coils

The coils feature a zinc-nickel surface treatment.

The WK7D coil includes a suppressor diode of pulses for protection from voltage peaks during switching. During the switching the diode significantly reduces the energy released by the winding, by limiting the voltage to 31.4V in the D12 coil and to 58.9 V in the D24 coil.

(values $\pm 10\%$)

	Nominal voltage [V]	Resistance at 20°C [Ω]	Current consumpt. [A]	Power consumpt [W]	Coil code		
					WK1	WK7	WK7D
D12	12	4,4	2,72	32,7	1903050	1903580	1903600
D24	24	18,6	1,29	31	1903051	1903581	1903601

16.4 - Protection from atmospheric agents IEC 60529

The IP protection degree is guaranteed only with both valve and connectors of an equivalent IP grade, correctly connected and installed.

electric connection	electric connection protection	whole valve protection
WK1 EN 175301-803 (ex DIN 43650)	IP66	IP65
WK7 DEUTSCH DT04 male	IP66/IP68/IP69 IP69K*	IP66/IP68/IP69 IP69K*
WK7D DEUTSCH DT04 male	IP66/IP68/IP69 IP69K*	IP66/IP68/IP69 IP69K*

(*) The IP69K protection degree is not taken into account in IEC 60529 but it is included in ISO 20653.

17- PORT RESTRICTORS

Port restrictors are recommended if flow variations occur which exceed the valve performance limit during the switching processes, or for circuit dampening.

The port restrictor plugs can be ordered separately with the part numbers shown at left.

Ø (mm)	part number
blank	0144162
0.6	0144163
0.8	0144033
1	0144034

Ø (mm)	part number
1.2	0144035
1.5	0144036
1.8	0144164
2	0144165

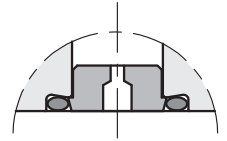

18 - SPARE PARTS FOR DC SOLENOID VALVE

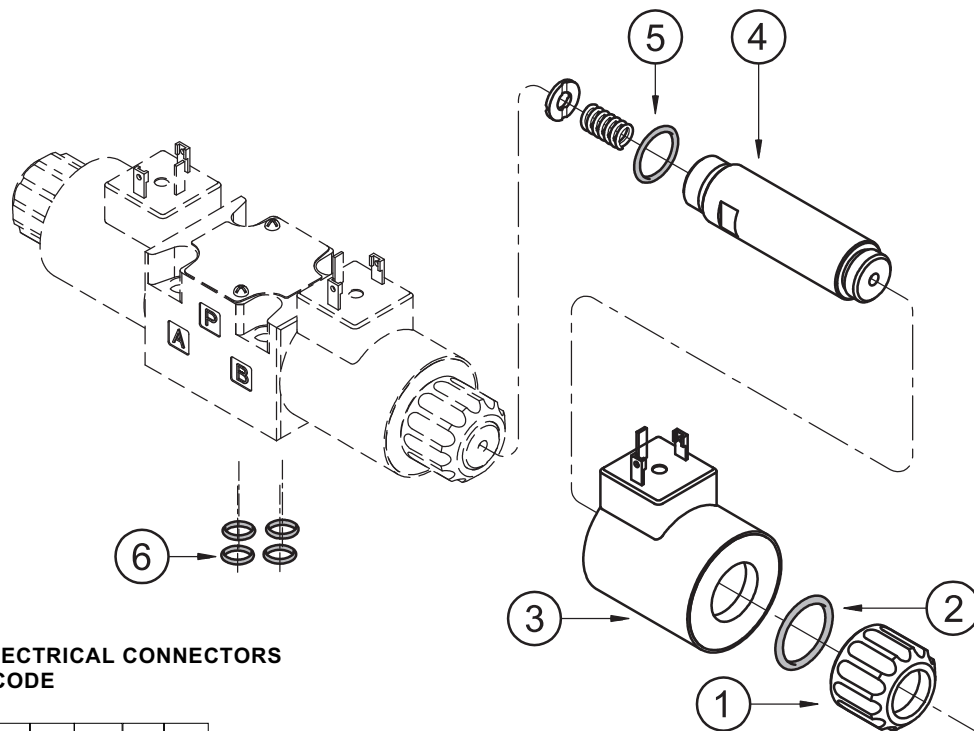

DC COILS AND ELECTRICAL CONNECTORS IDENTIFICATION CODE

C 22S3 - /

Supply voltage

- D12** = 12 V
- D14** = 14 V
- D24** = 24 V
- D28** = 28 V
- D48** = 48 V
- D125** = 125 V
- D110** = 110 V
- D220** = 220 V

Series no.:

- 10** = for K7 and WK7
- 11** = for K1 up to D48, K2 and WK1
- 12** = for K1 D110, D125, D220 and WK7D

Coil electrical connection (see par. 11):

K1 = plug for connector type EN 175301-803 (ex DIN 43650)

D12 and **D24** coils only:

K2 = plug for connector AMP JUNIOR

K7 = plug DEUTSCH DT04-2P for male connector DEUTSCH DT06-2S

W7 version

WK1 = plug for connector type EN 175301-803 (ex DIN 43650)

WK7 = plug DEUTSCH DT04-2P, for male connector type DEUTSCH DT06-2S

WK7D = plug DEUTSCH DT04-2P, for male connector type DEUTSCH DT06-2S. Coil with diode

1	Coil locking ring with seal included cod. 0119412 Tightening torque 5 ±0.5 Nm
2	ORM type 0220-20 (22x2) - 70 Shore
3	Coil (see identification code)
4	Solenoid tube for standard version: TD22-DS3/10N (NBR seals) TD22-DS3/10V (FPM seals) Solenoid tube for version with soft-shifting: TD22-DS3F/10N (NBR seals) TD22-DS3F/10V (FPM seals) NOTE: OR n°5 included
5	OR type 2062 (15.6x1.78) - 70 Shore
6	4 OR type 2037 (9.25x1.78) - 90 Shore

SEALS KIT

The codes include the O-Ring n° 2, 5 and 6.

- Cod. 1985406** NBR seals
- Cod. 1985410** FPM (viton) seals

19 - SPARE PARTS FOR AC SOLENOID VALVE

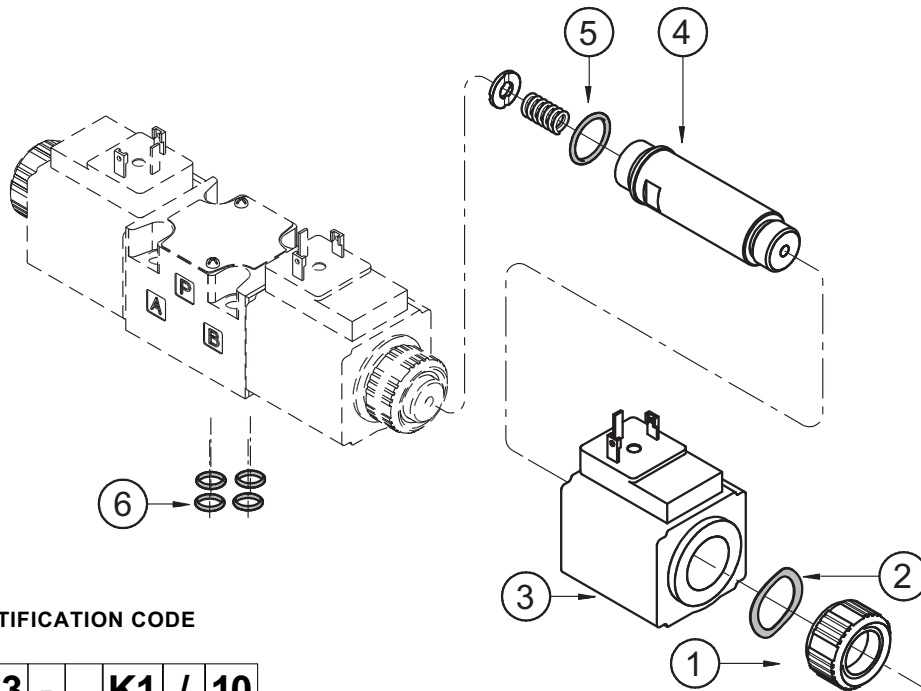

AC COILS IDENTIFICATION CODE

C 20.6S3 - K1 / 10

Supply voltage

- A24** = 24 V - 50 Hz
- A48** = 48 V - 50 Hz
- A100** = 100 V - 50 Hz
100 V - 60 Hz
- A110** = 110 V - 50 Hz
120 V - 60 Hz
- A230** = 230 V - 50 Hz
240 V - 60 Hz
- F110** = 110 V - 60 Hz
- F220** = 220 V - 60 Hz

Series no.:
(the overall and mounting dimensions remain unchanged from 10 to 19)

Plug for connector type
EN 175301-803

1	Coil locking ring cod. 0119333 Tightening torque 5 ±0.5 Nm
2	Snap ring cod. 0550483
3	Coil (see identification code on the side)
4	Solenoid tube : TA20.6-DS3/10N (NBR seals) TA20.6-DS3/10V (FPM seals) NOTE: OR n° 5 included
5	OR type 2062 (15.6x1.78) - 70 Shore
6	N. 4 OR type 2037 (9.25x1.78) - 90 Shore

SEALS KIT

The codes include the OR nr. 5 and 6.

- Cod. 1985406** NBR seals
- Cod. 1985410** FPM (viton) seals

20 - SUBPLATES

(see catalogue 51 000)

Type PMMD-AI3G with rear ports 3/8" BSP

Type PMMD-AL3G with side ports 3/8" BSP



DIPLOMATIC OLEODINAMICA S.p.A.

20015 PARABIAGO (MI) • Via M. Re Depaolini 24

Tel. +39 0331.895.111

Fax +39 0331.895.339

www.diplomatic.com • e-mail: sales.exp@diplomatic.com